

**Makita**<sup>®</sup>

new

Portable Band Saw  
2107F



**Large 4-3/4" x 4-3/4" Capacity  
with Excellent Tool Balance.**

# Increased Rigidity

*Bridge construction of Aluminum frame and Motor housing makes the machine more durable.*



## Built-in Fluorescent Job Light

For clear view of ink line even in dark places. Switch for Fluorescent Job Light is independent of main switch.



## Preset Dial for Speed Adjustment

Enables you to obtain suitable strokes per minutes for each cutting material.



## Adjustable Stopper Plate

Retractable when cutting pipes near the wall or the floor, increasing maneuverability.



## SPECIFICATIONS

Continuous rating Input Capacity	710 W Round workpiece : 120 mm (4-3/4") dia Rectangular workpiece without stand : 120 mm x 120 mm (4-3/4" x 4-3/4")
Blade speed	60 m (200 ft.) / min. - 105 m (350 ft.) / min.
Overall length	508 mm (20")
Net weight	5.7 kg (12.6 lbs)
Power supply cord	2.5 m (8.2 ft.)



Specifications may differ from country to country.

## STANDARD EQUIPMENT

	Part No.
Carbon steel band saw blade (18 teeth per inch) 1 pc	*792559-8
Hex. wrench	783202-0

Items of standard equipment may differ from country to country. \* 3pcs/set part No.

## OPTIONAL ACCESSORIES

### Band saw blade

Width : 13 mm  
Thickness : 0.5 mm  
Length : 1,140 mm



Kind of blade	Thickness of work-piece to be cut	No. of teeth per inch	Application	Part No.
Carbon steel (3pcs./set)	More than 5 mm	6	Wood	792567-9
	4 mm-5 mm	14	Plastics non-ferrous metal	792560-3
	Less than 4 mm	18	Mild steel, cast steel cast iron	792559-8
Highspeed steel (1pc./set)	4 mm-5 mm	24	Plastics, non-ferrous metal	792558-0
	More than 5 mm	14	Mild steel, cast steel cast iron, Hard steel	792557-2
	Less than 4 mm	18	stainless steel	792556-4
		24		792555-6

### Portable band saw stand

(For accurate square cutting operations)

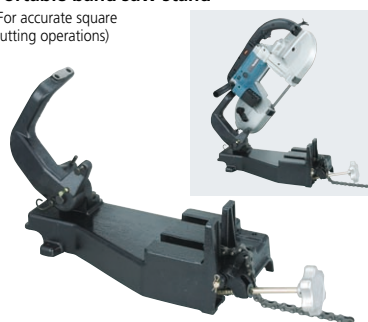

Part No. 194026-3

### Cover



Part No. 194070-0

### Portable band saw stand and Cover set

Part No. 194069-5